

ASSEMBLIES

Table of Contents

GEARBOXES - WORM WHEEL AND HELICAL GEARS		
TECHNICAL DATA - SPEED REDUCERS	MC 2	
WORM & WORM WHEEL GEAR BOXES		
SHAFT SIZE - 3MM,4MM AND 6MM	MC3 - MC 4	
HELICAL GEAR BOXES	MC 5	
MINIATURE MITER GEARBOX	MC 6, MC 8, MC9	
BEVEL GEARBOX	MC 7, MC10	
SERVO GEARBOX		
SHAFT SIZE -3MM	MC 11	
SHAFT SIZE - 4MM	MC 12	
SHAFT SIZE - 6MM"	MC 13	
SPEED REDUCER		
SHAFT SIZE - 3MM	MC 14	
SHAFT SIZE - 6MM	MC 15	
PRECISION PLANETARY GEAR HEADS		
SHAFT SIZE -16MM, 20MM AND 24MM	MC 16	
INTERMITTENT MOTION ASSEMBLY		
SHAFT SIZE - 6MM	MC 17	
GENEVA MECHANISM		
SHAFT SIZE - 6MM AND 7MM	MC 18	
CAM FOLLOWERS	MC 19	
ROLLER BEARING CAM FOLLOWER	MC 20	
RATCHETS AND PAWLS	MC 21	

C

GEARBOXES - WORM WHEEL AND HELICAL GEARS

TECHNICAL INFORMATION PRECISION SPEED REDUCERS 3mm, 4mm and 6mm Shafts

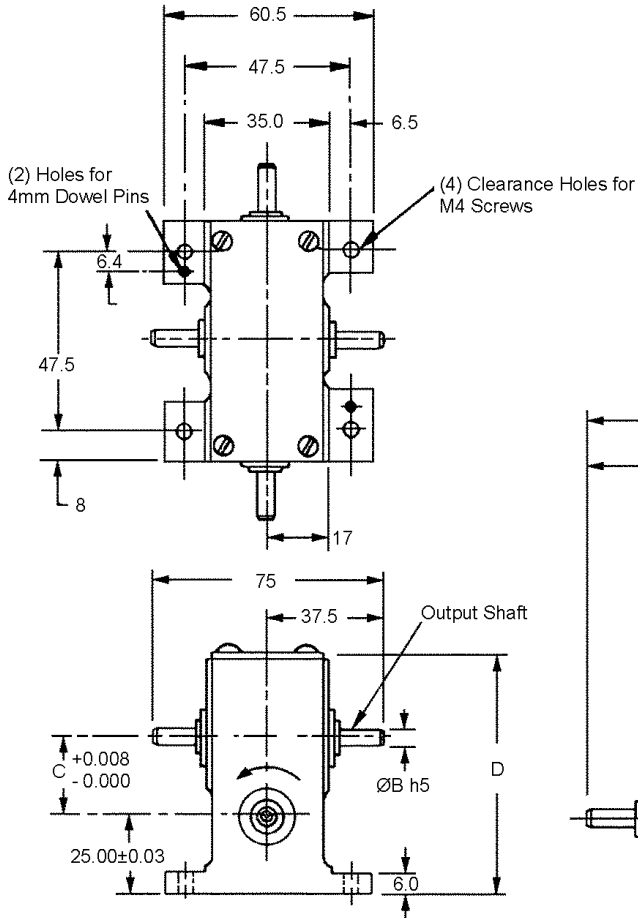

Materials

Housing	Cast Aluminum (Anodized)
Worm Wheel	Bronze
Worm	Stainless Steel
Helical Gear	Aluminum
Helical Pinion	Stainless Steel

Bearings	Stainless Steel or Bronze
Shafts	Stainless Steel
Lubrication	Grease
Housing Cover	Aluminum
All other parts	Stainless Steel

Backlash @ Output Shaft

Ball Bearing Unit	20 Minutes Max.
Bronze Bearing Unit	30 Minutes Max.

Maximum Output

3mm Shaft Series	- 177N·cm
4mm Shaft Series	- 247N·cm
6mm Shaft Series	- 353N·cm

Maximum Input Speed

2000 RPM

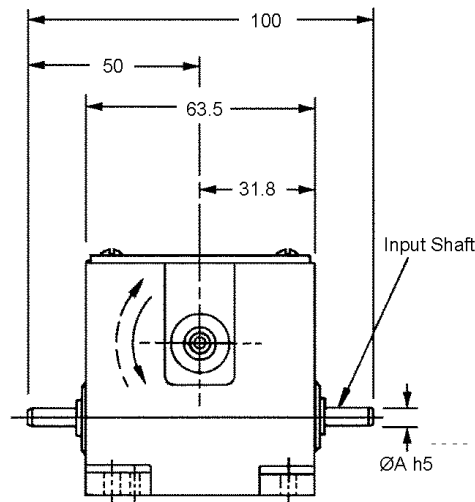

Worm and Wheel units can only be driven from input shaft and will only operate as a Speed Reducer.
Helical Gear units can be driven from input shaft as a Speed Reducer or from output shaft as a Speed Increaser.
Other ratios available on request.
Anti-Backlash unit available on request.



WORM & WHEEL GEAR BOXES

SHAFT SIZE	TYPE
ØA= 3MM ØB= 3MM	BALL BEARING OR BRONZE BEARING

BALL BEARINGS UNITS STOCK NO.	BRONZE BEARINGS UNITS STOCK NO.	UNIT TYPE	SHAFT SIZE		NOMINAL RATIO	C CENTER	D HEIGHT	MAXIMUM OUTPUT TORQUE (N•cm.)
			ØA	ØB				
WX64B2-1M	WX64P2-1M	WORM & WHEEL	3.00	3.00	15:1	18.263	59	79
WX64B2-2M	WX64P2-2M				20:1	22.233	66	112
WX64B2-3M	WX64P2-3M				25:1	26.200	75	135
WX64B2-4M	WX64P2-4M				30:1	30.170	82	169
WX64B2-5M	WX64P2-5M				30:1	18.263	59	101
WX64B2-6M	WX64P2-6M				40:1	22.233	66	135
WX64B2-7M	WX64P2-7M				50:1	26.200	75	169
WX64B2-8M	WX64P2-8M				60:1	30.170	72	203
WX64B2-9M	WX64P2-9M				60:1	18.263	59	101
WX64B2-10M	WX64P2-10M				80:1	22.233	66	135
WX64B2-11M	WX64P2-11M				100:1	26.200	75	169
WX64B2-12M	WX64P2-12M				120:1	30.170	82	203

C

SHAFT SIZE	TYPE
ØA= 4MM ØB= 4MM	BALL BEARING OR BRONZE BEARING

BALL BEARINGS UNITS STOCK NO.	BRONZE BEARINGS UNITS STOCK NO.	UNIT TYPE	SHAFT SIZE		NOMINAL RATIO	C CENTER	D HEIGHT	MAXIMUM OUTPUT TORQUE (N•cm.)
			ØA	ØB				
WX64B3-1M	WX64P3-1M	WORM & WHEEL	4.00	4.00	15:1	18.263	59	79
WX64B3-2M	WX64P3-2M				20:1	22.233	66	112
WX64B3-3M	WX64P3-3M				25:1	26.200	75	135
WX64B3-4M	WX64P3-4M				30:1	30.170	82	169
WX64B3-5M	WX64P3-5M				30:1	18.263	59	101
WX64B3-6M	WX64P3-6M				40:1	22.233	66	135
WX64B3-7M	WX64P3-7M				50:1	26.200	75	169
WX64B3-8M	WX64P3-8M				60:1	30.170	72	203
WX64B3-9M	WX64P3-9M				60:1	18.263	59	101
WX64B3-10M	WX64P3-10M				80:1	22.233	66	135
WX64B3-11M	WX64P3-11M				100:1	26.200	75	169
WX64B3-12M	WX64P3-12M				120:1	30.170	82	203

SHAFT SIZE	TYPE
ØA= 6MM ØB= 6MM	BALL BEARING OR BRONZE BEARING

BALL BEARINGS UNITS STOCK NO.	BRONZE BEARINGS UNITS STOCK NO.	UNIT TYPE	SHAFT SIZE		NOMINAL RATIO	C CENTER	D HEIGHT	MAXIMUM OUTPUT TORQUE (N•cm.)
			ØA	ØB				
WX64B4-1M	WX64P4-1M	WORM & WHEEL	6.00	6.00	15:1	18.263	59	79
WX64B4-2M	WX64P4-2M				20:1	22.233	66	112
WX64B4-3M	WX64P4-3M				25:1	26.200	75	135
WX64B4-4M	WX64P4-4M				30:1	30.170	82	169
WX64B4-5M	WX64P4-5M				30:1	18.263	59	101
WX64B4-6M	WX64P4-6M				40:1	22.233	66	135
WX64B4-7M	WX64P4-7M				50:1	26.200	75	169
WX64B4-8M	WX64P4-8M				60:1	30.170	72	203
WX64B4-9M	WX64P4-9M				60:1	18.263	59	101
WX64B4-10M	WX64P4-10M				80:1	22.233	66	135
WX64B4-11M	WX64P4-11M				100:1	26.200	75	169
WX64B4-12M	WX64P4-12M				120:1	30.170	82	203

WORM & WHEEL GEAR BOXES

SHAFT SIZE	TYPE
ØA= 3MM ØB= 3MM	BALL BEARING OR BRONZE BEARING

BALL BEARINGS UNITS STOCK NO.	BRONZE BEARINGS UNITS STOCK NO.	UNIT TYPE	SHAFT SIZE		NOMINAL RATIO	C CENTER	D HEIGHT	MAXIMUM OUTPUT TORQUE (N•cm.)
			ØA	ØB				
WX48B2-1M	WX48P2-1M	WORM & WHEEL	3.00	3.00	12.5:1	17.470	59	101
WX48B2-2M	WX48P2-2M				15:1	20.117	64	124
WX48B2-3M	WX48P2-3M				20:1	25.408	75	164
WX48B2-4M	WX48P2-4M				22.5:1	28.054	80	192
WX48B2-5M	WX48P2-5M				25:1	17.470	59	124
WX48B2-6M	WX48P2-6M				30:1	20.117	64	146
WX48B2-7M	WX48P2-7M				40:1	25.408	75	203
WX48B2-8M	WX48P2-8M				45:1	28.054	80	225
WX48B2-9M	WX48P2-9M				50:1	17.470	59	124
WX48B2-10M	WX48P2-10M				60:1	20.117	64	146
WX48B2-11M	WX48P2-11M				80:1	25.408	75	203
WX48B2-12M	WX48P2-12M				90:1	28.054	80	225

SHAFT SIZE	TYPE
ØA= 4MM ØB= 4MM	BALL BEARING OR BRONZE BEARING

BALL BEARINGS UNITS STOCK NO.	BRONZE BEARINGS UNITS STOCK NO.	UNIT TYPE	SHAFT SIZE		NOMINAL RATIO	C CENTER	D HEIGHT	MAXIMUM OUTPUT TORQUE (N•cm.)
			ØA	ØB				
WX48B3-1M	WX48P3-1M	WORM & WHEEL	4.00	4.00	12.5:1	17.470	59	101
WX48B3-2M	WX48P3-2M				15:1	20.117	64	124
WX48B3-3M	WX48P3-3M				20:1	25.408	75	164
WX48B3-4M	WX48P3-4M				22.5:1	28.054	80	192
WX48B3-5M	WX48P3-5M				25:1	17.470	59	124
WX48B3-6M	WX48P3-6M				30:1	20.117	64	146
WX48B3-7M	WX48P3-7M				40:1	25.408	75	203
WX48B3-8M	WX48P3-8M				45:1	28.054	80	225
WX48B3-9M	WX48P3-9M				50:1	17.470	59	124
WX48B3-10M	WX48P3-10M				60:1	20.117	64	146
WX48B3-11M	WX48P3-11M				80:1	25.408	75	203
WX48B3-12M	WX48P3-12M				90:1	28.054	80	225

SHAFT SIZE	TYPE
ØA= 6MM ØB= 6MM	BALL BEARING OR BRONZE BEARING

BALL BEARINGS UNITS STOCK NO.	BRONZE BEARINGS UNITS STOCK NO.	UNIT TYPE	SHAFT SIZE		NOMINAL RATIO	C CENTER	D HEIGHT	MAXIMUM OUTPUT TORQUE (N•cm.)
			ØA	ØB				
WX48B4-1M	WX48P4-1M	WORM & WHEEL	6.00	6.00	12.5:1	17.470	59	101
WX48B4-2M	WX48P4-2M				15:1	20.117	64	124
WX48B4-3M	WX48P4-3M				20:1	25.408	75	164
WX48B4-4M	WX48P4-4M				22.5:1	28.054	80	192
WX48B4-5M	WX48P4-5M				25:1	17.470	59	124
WX48B4-6M	WX48P4-6M				30:1	20.117	64	146
WX48B4-7M	WX48P4-7M				40:1	25.408	75	203
WX48B4-8M	WX48P4-8M				45:1	28.054	80	225
WX48B4-9M	WX48P4-9M				50:1	17.470	59	124
WX48B4-10M	WX48P4-10M				60:1	20.117	64	146
WX48B4-11M	WX48P4-11M				80:1	25.408	75	203
WX48B4-12M	WX48P4-12M				90:1	28.054	80	225

HELICAL GEAR BOXES

SHAFT SIZE				TYPE			
ØA= 3MM		ØB= 3MM		BALL BEARING OR BRONZE BEARING			

BALL BEARINGS UNITS STOCK NO.	BRONZE BEARINGS UNITS STOCK NO.	UNIT TYPE	SHAFT SIZE		NOMINAL RATIO	C CENTER	D HEIGHT	MAXIMUM OUTPUT TORQUE (N•cm)
			ØA	ØB				
HX64B2-1M	HX64P2-1M	HELICAL	3.00	3.00	1:1	11.232	45	34
HX64B2-2M	HX64P2-2M				2:1	16.845	56	
HX64B2-3M	HX64P2-3M				3:1	22.456	68	
HX64B2-4M	HX64P2-4M				4:1	28.070	79	

SHAFT SIZE				TYPE			
ØA= 4MM		ØB= 4MM		BALL BEARING OR BRONZE BEARING			

BALL BEARINGS UNITS STOCK NO.	BRONZE BEARINGS UNITS STOCK NO.	UNIT TYPE	SHAFT SIZE		NOMINAL RATIO	C CENTER	D HEIGHT	MAXIMUM OUTPUT TORQUE (N•cm)
			ØA	ØB				
HX64B3-1M	HX64P3-1M	HELICAL	4.00	4.00	1:1	11.232	45	51
HX64B3-2M	HX64P3-2M				2:1	16.845	56	
HX64B3-3M	HX64P3-3M				3:1	22.456	68	
HX64B3-4M	HX64P3-4M				4:1	28.070	79	

SHAFT SIZE				UNITS			
ØA= 4MM		ØB= 4MM		BALL BEARING OR BRONZE BEARING			

BALL BEARINGS UNITS STOCK NO.	BRONZE BEARINGS UNITS STOCK NO.	UNIT TYPE	SHAFT SIZE		NOMINAL RATIO	C CENTER	D HEIGHT	MAXIMUM OUTPUT TORQUE (N•cm.)
			ØA	ØB				
HX48B3-1M	HX48P3-1M	HELICAL	4.00	4.00	1:1	14.973	51	51
HX48B3-2M	HX48P3-2M				2:1	22.456	65	
HX48B3-3M	HX48P3-3M				3:1	29.939	55	

SHAFT SIZE				UNITS			
ØA= 6MM		ØB= 6MM		BALL BEARING OR BRONZE BEARING			

BALL BEARINGS UNITS STOCK NO.	BRONZE BEARINGS UNITS STOCK NO.	UNIT TYPE	SHAFT SIZE		NOMINAL RATIO	C CENTER	D HEIGHT	MAXIMUM OUTPUT TORQUE (N•cm.)
			ØA	ØB				
HX48B4-1M	HX48P4-1M	HELICAL	6.00	6.00	1:1	14.973	51	91
HX48B4-2M	HX48P4-2M				2:1	22.456	65	
HX48B4-3M	HX48P4-3M				3:1	29.939	55	

MINIATURE MITER GEARBOX

SHAFT SIZE	TYPE
4MM	BRONZE BEARING

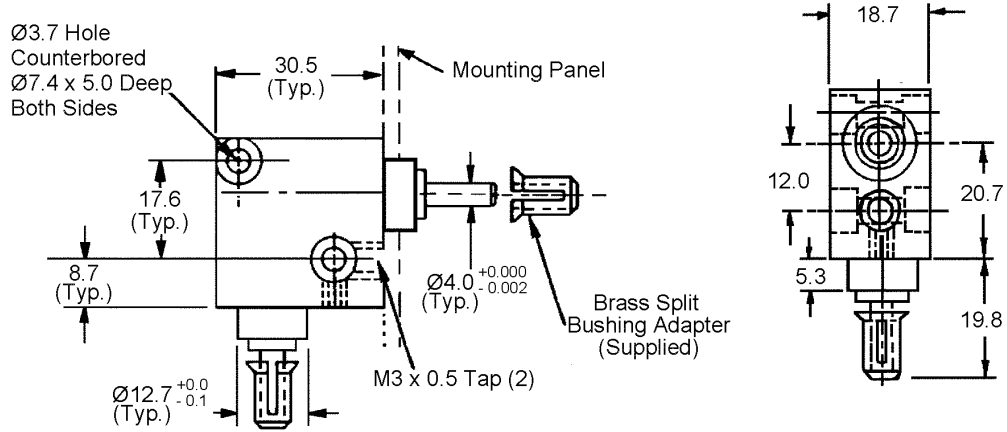

STOCK NO.	GEAR MATERIAL	OPERATING TORQUE
MX-14M	HARDENED STEEL	140N•cm

- Ground and hardened steel shafts
- Sintered bronze bearing system
- Gearbox and bearings lubricated for life
- 1000 RPM Maximum

BEVEL GEARBOX

SHAFT SIZE	RATIOS	TYPE
5MM	1:1 and 1:2	BRONZE BEARING

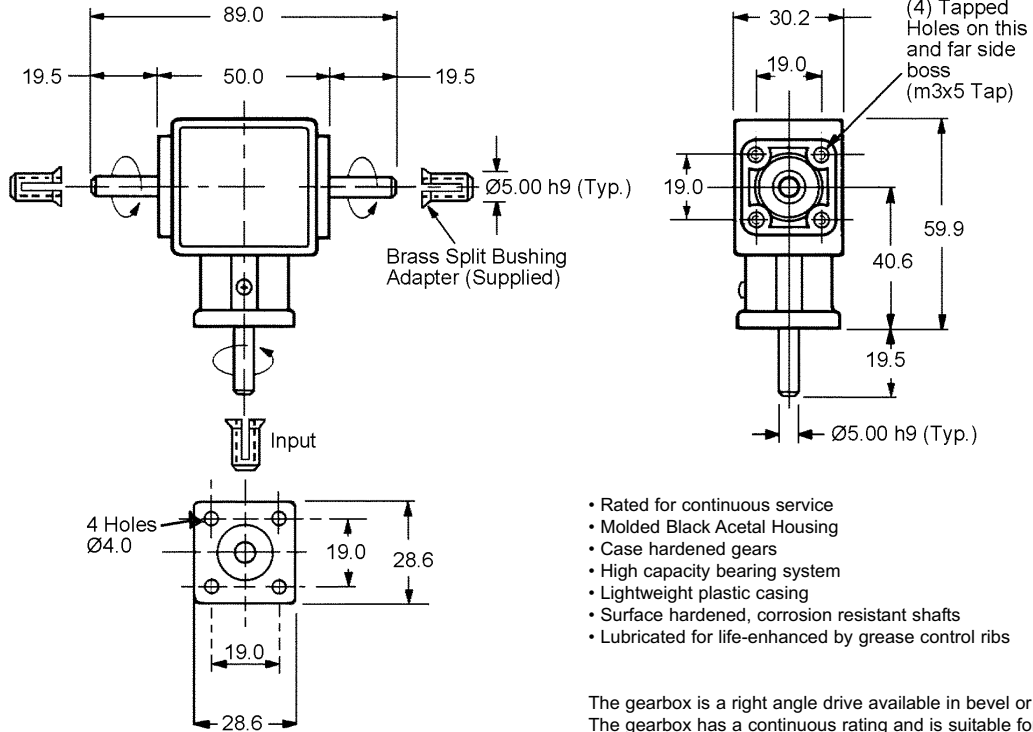

- Rated for continuous service
- Molded Black Acetal Housing
- Case hardened gears
- High capacity bearing system
- Lightweight plastic casing
- Surface hardened, corrosion resistant shafts
- Lubricated for life-enhanced by grease control ribs

The gearbox is a right angle drive available in bevel or miter gear versions. The gearbox has a continuous rating and is suitable for instrument and light duty drives. It is both economical and reliable.

STOCK NO.	RATIO	RPM MAX.	OPERATING TORQUE	BACKLASH MAX.
MX-16M	1:1	1500	30N•cm	2°
MX-17M	1:2	1500	65N•cm	2°

MITER GEARBOX

SHAFT SIZE	RATIO	TYPE
3MM	1:1	BALL BEARING OR BRONZE BEARING

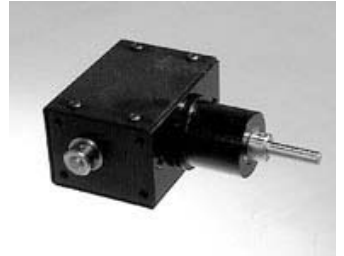
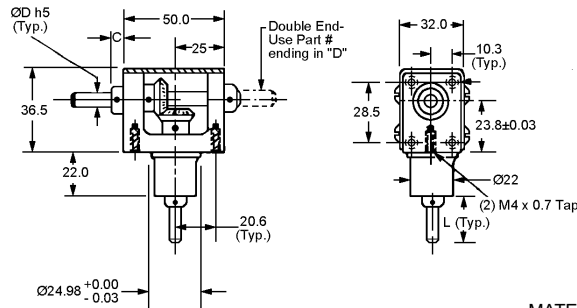

Consult Berg's Engineering Department for higher torque units.

ABEC 7 BALL BEARING	OIL-LESS BRONZE BEARING UNIT	SHAFT $\varnothing D$	C	L	SHAFT END STYLE	R.P.M. (MAX.)	TORQUE (MAX.)
STOCK NO.	STOCK NO.						
MX-101	MX-101B	2.993	4.76	18.0	SINGLE	1000	140N•cm
MX-101-D	MX-101B-D				DOUBLE		

MATERIAL:
 Housing: Aluminum
 Shafts and Hardware: Stainless Steel
 Bearings: Stainless Steel or Bronze
 Gears: Stainless Steel and Aluminum
 Lubrication: MIL. Spec. Oil and Grease

SHAFT SIZE	RATIO	TYPE
4MM	1:1	BALL BEARING OR BRONZE BEARING

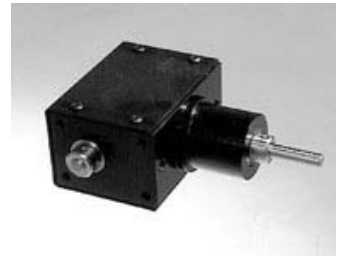
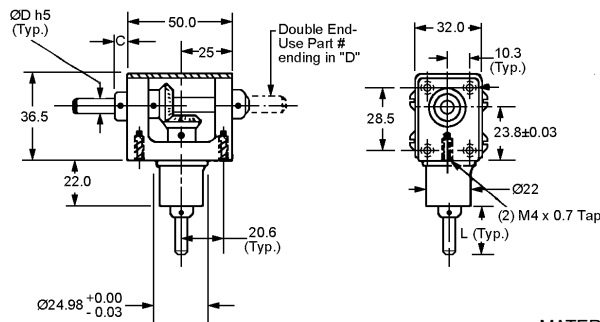

Consult Berg's Engineering Department for higher torque units.

ABEC 7 BALL BEARING	OIL-LESS BRONZE BEARING UNIT	SHAFT $\varnothing D$	C	L	SHAFT END STYLE	R.P.M. (MAX.)	TORQUE (MAX.)
STOCK NO.	STOCK NO.						
MX-102	MX-102B	3.993	5.59	22.0	SINGLE	2000	210N•cm
MX-102-D	MX-102B-D				DOUBLE		

MATERIAL:
 Housing: Aluminum
 Shafts and Hardware: Stainless Steel
 Bearings: Stainless Steel or Bronze
 Gears: Stainless Steel and Aluminum
 Lubrication: MIL. Spec. Oil and Grease

SHAFT SIZE	RATIO	TYPE
6MM	1:1	BALL BEARING OR BRONZE BEARING

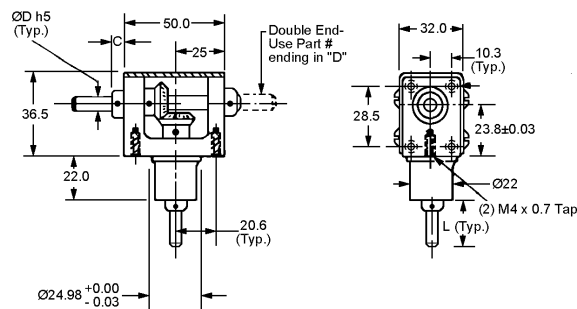

Consult Berg's Engineering Department for higher torque units.

ABEC 7 BALL BEARING	OIL-LESS BRONZE BEARING UNIT	SHAFT $\varnothing D$	C	L	SHAFT END STYLE	R.P.M. (MAX.)	TORQUE (MAX.)
STOCK NO.	STOCK NO.						
MX-103	MX-103B	5.993	6.35	26.0	SINGLE	2500	350N•cm
MX-103-D	MX-103B-D				DOUBLE		

MATERIAL:
 Housing: Aluminum
 Shafts and Hardware: Stainless Steel
 Bearings: Stainless Steel or Bronze
 Gears: Stainless Steel and Aluminum
 Lubrication: MIL. Spec. Oil and Grease

MINIATURE MITER GEARBOX

SHAFT SIZE	RATIO	TYPE
3MM	1:1	BALL BEARING OR BRONZE BEARING

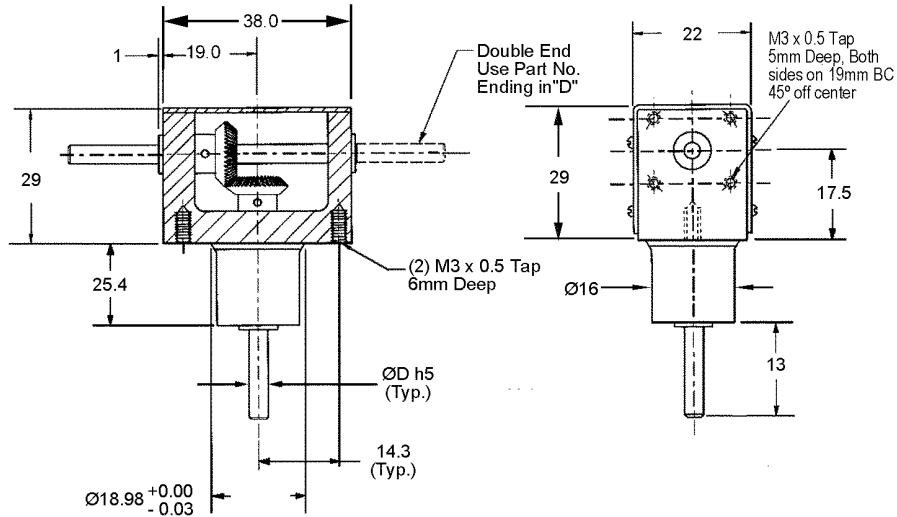

MATERIAL:
 Housing Aluminum
 Shafts and Hardware Stainless Steel
 Bearings Stainless Steel or Bronze
 Gears Stainless Steel
 Lubrication Grease

ABEC 7 BALL BEARING	OIL-LESS BRONZE BEARING UNIT	ØD	SHAFT END STYLE	R.P.M. (MAX.)	TORQUE (MAX.)
STOCK NO.	STOCK NO.				
MX-4M	MX-4BM	3.00	SINGLE	1000	70N•cm
MX-4M-D	MX-4BM-D		DOUBLE		

Consult Berg's Engineering Department for higher torque units.
 Anti-Backlash units available on request.

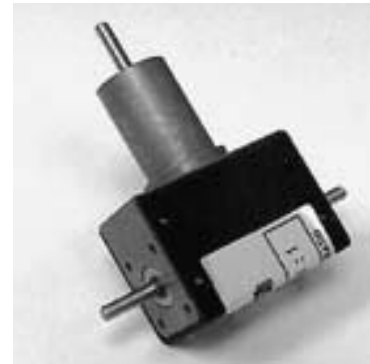

C

BEVEL GEARBOX

SHAFT SIZE	RATIO	TYPE
3MM	FROM 1:1 TO 1:3	BALL BEARING OR BRONZE BEARING

ABEC 7 BALL BEARING	OIL-LESS BRONZE BEARING UNIT	NOMINAL RATIO	ØD	B	C	E	F	G	H	A	RPM (MAX.)	STATIC TORQUE (MAX.)
STOCK NO.	STOCK NO.											
MX-5M MX-6M MX-7M	MX-5BM MX-6BM MX-7BM	1:1 1:2 1:3	3.00	70	48	41	48	21	37 43 49	25	1000	42N•cm

- Maximum backlash 10 minutes
- Units can be driven in either direction from any shaft

MATERIAL:
 Housing Aluminum
Shafts and Hardware Stainless Steel
Bearings Stainless Steel or Bronze
Gears Stainless Steel and Aluminum
Lubrication Grease

SHAFT SIZE	RATIO	TYPE
4MM	FROM 1:1 TO 1:3	BALL BEARING OR BRONZE BEARING

ABEC 7 BALL BEARING	OIL-LESS BRONZE BEARING UNIT	NOMINAL RATIO	ØD	B	C	E	F	G	H	A	RPM (MAX.)	STATIC TORQUE (MAX.)
STOCK NO.	STOCK NO.											
MX-8M MX-9M MX-10M	MX-8BM MX-9BM MX-10BM	1:1 1:2 1:3	4.00	70	48	41	48	21	37 43 49	25	2000	57N•cm

- Maximum backlash 10 minutes
- Units can be driven in either direction from any shaft

MATERIAL:
 Housing Aluminum
Shafts and Hardware Stainless Steel
Bearings Stainless Steel or Bronze
Gears Stainless Steel and Aluminum
Lubrication Grease

SHAFT SIZE	RATIO	TYPE
6MM	FROM 1:1 TO 1:3	BALL BEARING OR BRONZE BEARING

ABEC 7 BALL BEARING	OIL-LESS BRONZE BEARING UNIT	NOMINAL RATIO	ØD	B	C	E	F	G	H	A	RPM (MAX.)	STATIC TORQUE (MAX.)
STOCK NO.	STOCK NO.											
MX-11M MX-12M MX-13M	MX-11BM MX-12BM MX-13BM	1:1 1:2 1:3	6.00	89	67	51	57	24	51 59 65	38	2500	71N•cm

- Maximum backlash 10 minutes
- Units can be driven in either direction from any shaft

MATERIAL:
 Housing Aluminum
Shafts and Hardware Stainless Steel
Bearings Stainless Steel or Bronze
Gears Stainless Steel and Aluminum
Lubrication Grease

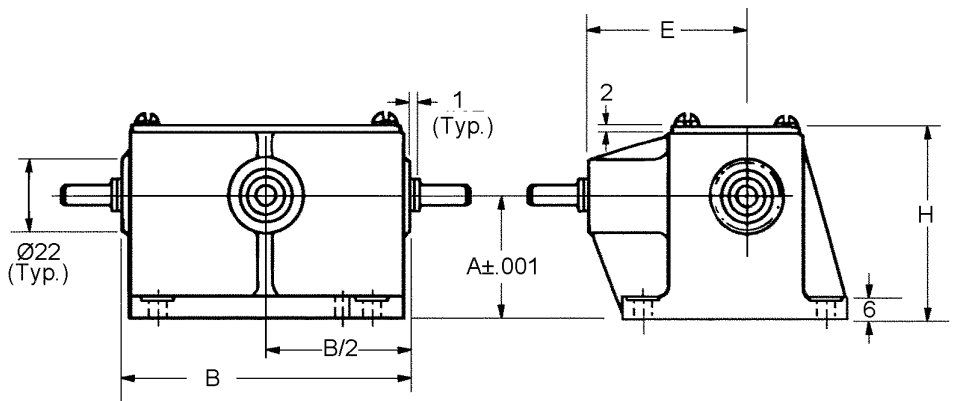
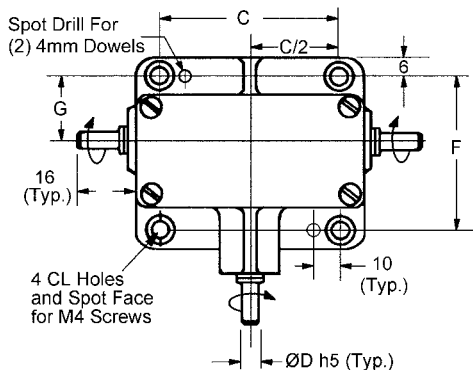

SERVO GEARBOX - PRECISION SPEED REDUCER

SHAFT SIZE	TYPE
3MM	BALL BEARING OR BRONZE BEARING

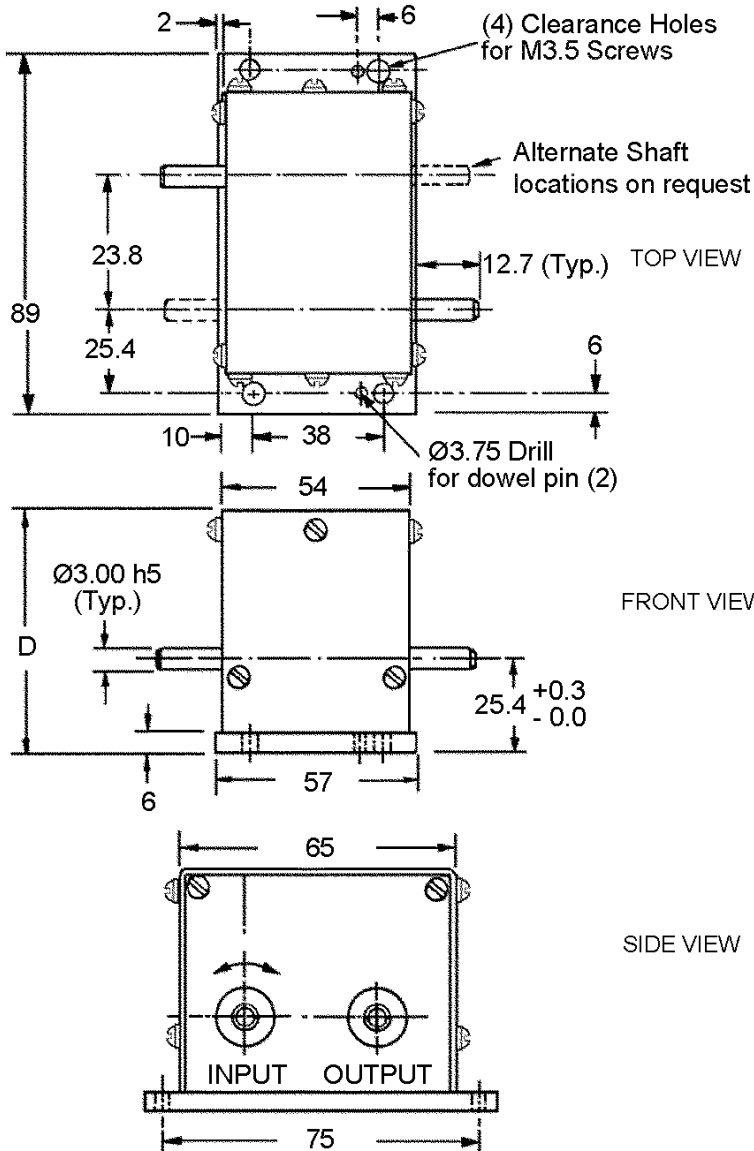

Special units available on request.
 Anti-Backlash gear - Output End
 Slip Clutch included - Input End
 Contact Berg's Engineering Department for recommendations for use as a Speed Increaser.

• See instructions below to order alternate shaft locations.

ABEC 7 BALL BEARINGS UNITS	BRONZE BEARINGS UNITS	NOMINAL RATIO	D HEIGHT	DIRECTION ROTATION
SX-B2-1M	SX-P2-1M	2:1	63.5	SAME
SX-B2-2M	SX-P2-2M	3:1		
SX-B2-3M	SX-P2-3M	4:1		
SX-B2-4M	SX-P2-4M	5:1		
SX-B2-5M	SX-P2-5M	6:1		
SX-B2-6M	SX-P2-6M	7:1		
SX-B2-7M	SX-P2-7M	8:1		
SX-B2-8M	SX-P2-8M	9:1		
SX-B2-9M	SX-P2-9M	10:1		
SX-B2-10M	SX-P2-10M	12:1		
SX-B2-11M	SX-P2-11M	15:1		
SX-B2-12M	SX-P2-12M	16:1		
SX-B2-13M	SX-P2-13M	20:1		
SX-B2-14M	SX-P2-14M	25:1		
SX-B2-15M	SX-P2-15M	30:1	67.0	OPPOSITE
SX-B2-16M	SX-P2-16M	32:1		
SX-B2-17M	SX-P2-17M	36:1		
SX-B2-18M	SX-P2-18M	40:1		
SX-B2-19M	SX-P2-19M	45:1		
SX-B2-20M	SX-P2-20M	48:1		
SX-B2-21M	SX-P2-21M	50:1		
SX-B2-22M	SX-P2-22M	60:1		
SX-B2-23M	SX-P2-23M	64:1		
SX-B2-24M	SX-P2-24M	75:1		
SX-B2-25M	SX-P2-25M	80:1		
SX-B2-26M	SX-P2-26M	100:1		
SX-B2-27M	SX-P2-27M	125:1		
SX-B2-28M	SX-P2-28M	72:1	84.0	SAME
SX-B2-29M	SX-P2-29M	90:1		
SX-B2-30M	SX-P2-30M	96:1		
SX-B2-31M	SX-P2-31M	128:1		
SX-B2-32M	SX-P2-32M	150:1		
SX-B2-33M	SX-P2-33M	180:1		
SX-B2-34M	SX-P2-34M	200:1		
SX-B2-35M	SX-P2-35M	250:1		
SX-B2-36M	SX-P2-36M	256:1		
SX-B2-37M	SX-P2-37M	300:1		
SX-B2-38M	SX-P2-38M	375:1		
SX-B2-39M	SX-P2-39M	400:1		
SX-B2-40M	SX-P2-40M	500:1		
SX-B2-41M	SX-P2-41M	625:1		

Alternate Shaft Locations

Add Style Letter to complete stock number, if different from that shown.

Style:

- = Opposite of as shown
- R = In and Out on R.H. side only
- L = In and Out on L.H. side only
- A = In and Out on all sides

Send drawing if other than listed above.

Materials

Housing and Cover Aluminum Anodized

Gears Stainless Steel and Aluminum

Shafts and Hardware Stainless Steel

Bearings Stainless Steel or Bronze

Lubrication Grease

Maximum Speed

5000 RPM

Maximum Output Torque

212N·cm



SERVO GEARBOXES

SHAFT SIZE	TYPE
4MM	BALL BEARING OR BRONZE BEARING

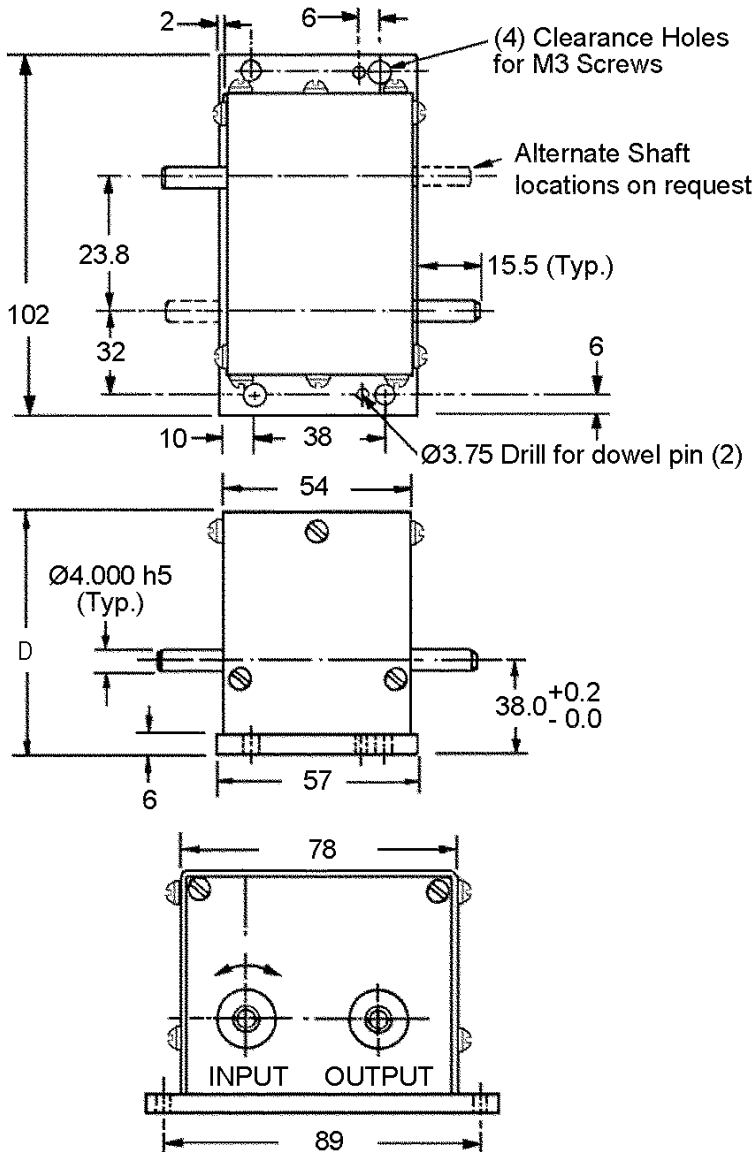

Special units available on request.

Anti-Backlash gear - Output End

Slip Clutch included - Input End

Contact Berg's Engineering Department for recommendations for use as a Speed Increaser.

• See instructions below to order alternate shaft locations.

ABEC 7 BALL BEARINGS UNITS	BRONZE BEARINGS UNITS	NOMINAL RATIO	D HEIGHT	DIRECTION ROTATION
STOCK NO.	STOCK NO.			
SX-B3-1M	SX-P3-1	2:1	86.0	SAME
SX-B3-2M	SX-P3-2	3:1		
SX-B3-3M	SX-P3-3	4:1		
SX-B3-4M	SX-P3-4	5:1		
SX-B3-5M	SX-P3-5	6:1		
SX-B3-6M	SX-P3-6	7:1		
SX-B3-7M	SX-P3-7	8:1		
SX-B3-8M	SX-P3-8	9:1		
SX-B3-9M	SX-P3-9	10:1		
SX-B3-10M	SX-P3-10	12:1		
SX-B3-11M	SX-P3-11	15:1		
SX-B3-12M	SX-P3-12	16:1		
SX-B3-13M	SX-P3-13	20:1		
SX-B3-14M	SX-P3-14	25:1		
SX-B3-15M	SX-P3-15	30:1	86.0	OPPOSITE
SX-B3-16M	SX-P3-16	32:1		
SX-B3-17M	SX-P3-17	36:1		
SX-B3-18M	SX-P3-18	40:1		
SX-B3-19M	SX-P3-19	45:1		
SX-B3-20M	SX-P3-20	48:1		
SX-B3-21M	SX-P3-21	50:1		
SX-B3-22M	SX-P3-22	60:1		
SX-B3-23M	SX-P3-23	64:1		
SX-B3-24M	SX-P3-24	75:1		
SX-B3-25M	SX-P3-25	80:1		
SX-B3-26M	SX-P3-26	100:1		
SX-B3-27M	SX-P3-27	125:1		
SX-B3-28M	SX-P3-28	72:1	109.0	SAME
SX-B3-29M	SX-P3-29	90:1		
SX-B3-30M	SX-P3-30	96:1		
SX-B3-31M	SX-P3-31	128:1		
SX-B3-32M	SX-P3-32	150:1		
SX-B3-33M	SX-P3-33	180:1		
SX-B3-34M	SX-P3-34	200:1		
SX-B3-35M	SX-P3-35	250:1		
SX-B3-36M	SX-P3-36	256:1		
SX-B3-37M	SX-P3-37	300:1		
SX-B3-38M	SX-P3-38	375:1		
SX-B3-39M	SX-P3-39	400:1		
SX-B3-40M	SX-P3-40	500:1		
SX-B3-41M	SX-P3-41	625:1		

Alternate Shaft Locations

Add **Style Letter** to complete stock number, if different from that shown.

Style:

- O** = Opposite of as shown
- R** = In and Out on R.H. side only
- L** = In and Out on L.H. side only
- A** = In and Out on all sides

Send drawing if other than listed above.

Backlash

At Output Shaft

Ball Bearing - 15 Minutes Max.

Bronze Bearing - 30 Minutes Max.

Materials

Housing and Cover Aluminum Anodized

Gears Stainless Steel and Aluminum

Shafts and Hardware Stainless Steel

Bearings Stainless Steel or Bronze

Lubrication Grease

Maximum Speed

5000 RPM

Maximum Output Torque

280N*cm



SERVO GEARBOXES

SHAFT SIZE	TYPE
6MM	BALL BEARING OR BRONZE BEARING

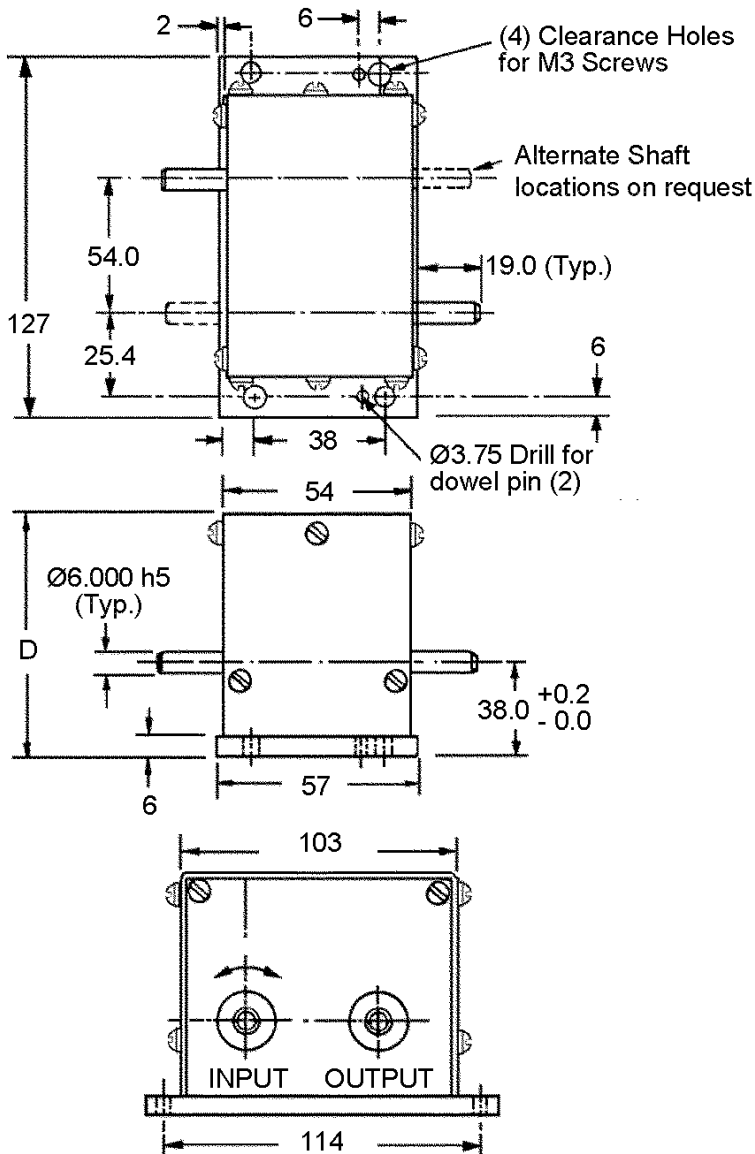

Special units available on request.

Anti-Backlash gear - Output End

Slip Clutch included - Input End

Contact Berg's Engineering Department for recommendations for use as a Speed Increaser.

• See instructions below to order alternate shaft locations.

ABEC 7 BALL BEARINGS UNITS	BRONZE BEARINGS UNITS	NOMINAL RATIO	D HEIGHT	DIRECTION ROTATION
SX-B4-1M	SX-P4-1M	2:1	83.5	SAME
SX-B4-2M	SX-P4-2M	3:1		
SX-B4-3M	SX-P4-3M	4:1		
SX-B4-4M	SX-P4-4M	5:1		
SX-B4-5M	SX-P4-5M	6:1		
SX-B4-6M	SX-P4-6M	7:1		
SX-B4-7M	SX-P4-7M	8:1		
SX-B4-8M	SX-P4-8M	9:1		
SX-B4-9M	SX-P4-9M	10:1		
SX-B4-10M	SX-P4-10M	12:1		
SX-B4-11M	SX-P4-11M	15:1		
SX-B4-12M	SX-P4-12M	16:1		
SX-B4-13M	SX-P4-13M	20:1		
SX-B4-14M	SX-P4-14M	25:1		
SX-B4-15M	SX-P4-15M	30:1	97.0	OPPOSITE
SX-B4-16M	SX-P4-16M	32:1		
SX-B4-17M	SX-P4-17M	36:1		
SX-B4-18M	SX-P4-18M	40:1		
SX-B4-19M	SX-P4-19M	45:1		
SX-B4-20M	SX-P4-20M	48:1		
SX-B4-21M	SX-P4-21M	50:1		
SX-B4-22M	SX-P4-22M	60:1		
SX-B4-23M	SX-P4-23M	64:1		
SX-B4-24M	SX-P4-24M	75:1		
SX-B4-25M	SX-P4-25M	80:1		
SX-B4-26M	SX-P4-26M	100:1		
SX-B4-27M	SX-P4-27M	125:1		
SX-B4-28M	SX-P4-28M	72:1	122.5	SAME
SX-B4-29M	SX-P4-29M	90:1		
SX-B4-30M	SX-P4-30M	96:1		
SX-B4-31M	SX-P4-31M	128:1		
SX-B4-32M	SX-P4-32M	150:1		
SX-B4-33M	SX-P4-33M	180:1		
SX-B4-34M	SX-P4-34M	200:1		
SX-B4-35M	SX-P4-35M	250:1		
SX-B4-36M	SX-P4-36M	256:1		
SX-B4-37M	SX-P4-37M	300:1		
SX-B4-38M	SX-P4-38M	375:1		
SX-B4-39M	SX-P4-39M	400:1		
SX-B4-40M	SX-P4-40M	500:1		
SX-B4-41M	SX-P4-41M	625:1		

Alternate Shaft Locations

Add **Style Letter** to complete stock number, if different from that shown.

Style:

- O** = Opposite of as shown
- R** = In and Out on R.H. side only
- L** = In and Out on L.H. side only
- A** = In and Out on all sides

Send drawing if other than listed above.

Backlash

At Output Shaft

Ball Bearing - 15 Minutes Max.

Bronze Bearing - 30 Minutes Max.

Materials

Housing and Cover Aluminum Anodized

Gears Stainless Steel and Aluminum

Shafts and Hardware Stainless Steel

Bearings Stainless Steel or Bronze

Lubrication Grease

Maximum Speed

5000 RPM

Maximum Output Torque

423N*cm



SPEED REDUCER

SHAFT	DIAMETER	BEARINGS	RATIOS
3MM	Ø27	ABEC -5	9:1 to 3600:1

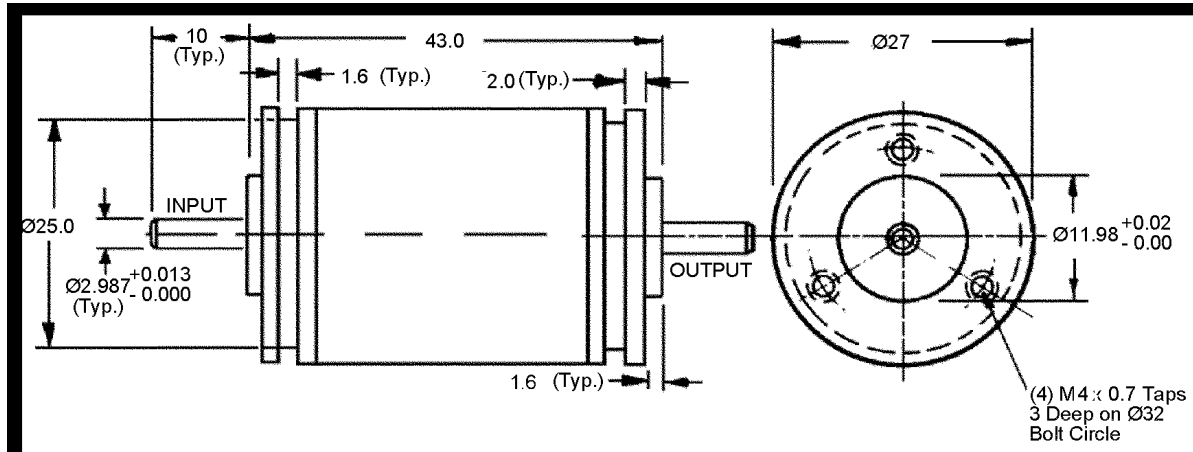

- Starting Torque (Max.) .004N·cm
- Rated Output Torque 46N·cm
- Maximum Backlash $0^{\circ} 30'$
- Moment of Inertia at Input Shaft 0.10mm
- Approximate Weight 220 gr.
- Ball Bearings On All Cluster Shafts



STOCK NO.	NOMINAL RATIO	NO. OF SHAFT ROTATION	GEAR CLUSTERS
RX11-1M	9:1	SAME	1
RX11-2M	10:1		
RX11-3M	12:1		
RX11-4M	15:1		
RX11-5M	20:1		
RX11-6M	25:1		
RX11-7M	30:1	OPPOSITE	2
RX11-8M	40:1	SAME	3
RX11-9M	50:1		
RX11-10M	60:1		
RX11-11M	80:1	OPPOSITE	4
RX11-12M	90:1		
RX11-13M	100:1		
RX11-14M	180:1		
RX11-15M	200:1	SAME	5
RX11-16M	300:1		
RX11-17M	360:1		
RX11-18M	400:1		
RX11-19M	500:1		
RX11-20M	600:1	OPPOSITE	6
RX11-21M	800:1		
RX11-22M	1000:1		
RX11-23M	2000:1		
RX11-24M	3000:1	SAME	5
RX11-25M	3600:1		

SPEED REDUCER

SHAFT	DIAMETER	BEARINGS	RATIOS
6MM	44.5MM	ABEC -5	4.96:1 to 3000:1

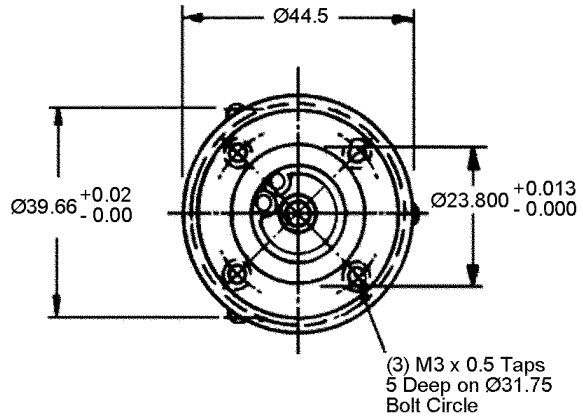
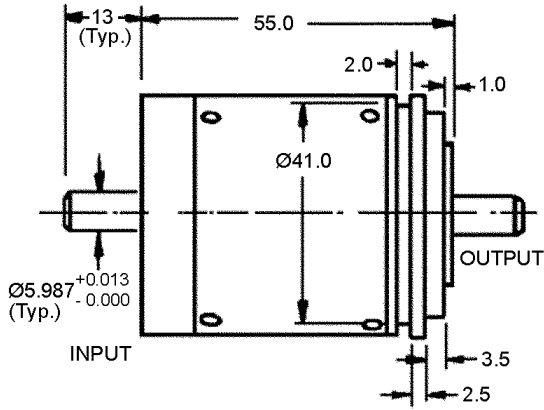

- Starting Torque (Max.) .02N.cm
- Rated Output Torque 88N.cm
- Maximum Backlash 0° 30'
- Shaft End Play (Max.) 2.5mm or .1mm
- Approximate Weight 85 gr.
- Ball Bearings On All Cluster Shafts



STOCK NO.	NOMINAL RATIO	NO. OF SHAFT ROTATION	GEAR CLUSTERS
RX18-1M	4.96:1	SAME	1
RX18-2M	6:1		
RX18-3M	9.93:1	OPPOSITE	2
RX18-4M	15.27:1		
RX18-5M	20:1	SAME	1
RX18-6M	30:1	OPPOSITE	2
RX18-7M	40:1		
RX18-8M	50.9:1		
RX18-9M	80:1		
RX18-10M	100:1	SAME	3
RX18-11M	124.8:1		
RX18-12M	150:1		
RX18-13M	200:1		
RX18-14M	248.16:1		
RX18-15M	300.3:1		
RX18-16M	400:1		
RX18-17M	500:1	OPPOSITE	4
RX18-18M	600:1		
RX18-19M	1000:1		
RX18-20M	1600:1	OPPOSITE	6
RX18-21M	1800:1		
RX18-22M	2000:1		
RX18-23M	2300:1		
RX18-24M	2500:1		
RX18-25M	3000:1	SAME	5

PRECISION PLANETARY GEAR HEADS

SHAFT SIZES			RATIOS
16	20	24	3:1 TO 100:1

NEMA PLANETARY GEARHEADS

STOCK NO.	RATIO	A	B	C	D	ØE	F	G	H	I	J	K	L	M	N	O	P	Q	R
GHPG60-3	3:1	60	5.0	70	50	16	25	2.5	13	80	5	26	78.2	3	16	18.0	5	1.0	22
GHPG60-5	5:1	60	5.0	70	50	16	25	2.5	13	80	5	26	78.2	3	16	18.0	5	1.0	22
GHPG60-8	8:1	60	5.0	70	50	16	25	2.5	13	80	5	26	78.2	3	16	18.0	5	1.0	22
GHPG60-10	10:1	60	5.0	70	50	16	25	2.5	13	80	5	26	78.2	3	16	18.0	5	1.0	22
GHPG60-15	15:1	60	5.0	70	50	16	25	2.5	13	80	5	26	78.2	3	16	18.0	5	1.0	22
GHPG60-20	20:1	60	5.0	70	50	16	25	2.5	13	80	5	26	78.2	3	16	18.0	5	1.0	22
GHPG60-30	30:1	60	5.0	70	50	16	25	2.5	13	80	5	26	78.2	3	16	18.0	5	1.0	22
GHPG60-50	50:1	60	5.0	70	50	16	25	2.5	13	80	5	26	78.2	3	16	18.0	5	1.0	22
GHPG60-100	100:1	60	5.0	70	50	16	25	2.5	13	80	5	26	78.2	3	16	18.0	5	1.0	22
GHPG90-3	3:1	90	6.5	100	80	20	40	2.5	12	116	7	34	95.3	5	28	22.5	6	1.0	36
GHPG90-5	5:1	90	6.5	100	80	20	40	2.5	12	116	7	34	95.3	5	28	22.5	6	1.0	36
GHPG90-8	8:1	90	6.5	100	80	20	40	2.5	12	116	7	34	95.3	5	28	22.5	6	1.0	36
GHPG90-10	10:1	90	6.5	100	80	20	40	2.5	12	116	7	34	95.3	5	28	22.5	6	1.0	36
GHPG90-15	15:1	90	6.5	100	80	20	40	2.5	12	116	7	34	95.3	5	28	22.5	6	1.0	36
GHPG90-20	20:1	90	6.5	100	80	20	40	2.5	12	116	7	34	95.3	5	28	22.5	6	1.0	36
GHPG90-30	30:1	90	6.5	100	80	20	40	2.5	12	116	7	34	95.3	5	28	22.5	6	1.0	36
GHPG90-50	50:1	90	6.5	100	80	20	40	2.5	12	116	7	34	95.3	5	28	22.5	6	1.0	36
GHPG90-100	100:1	90	6.5	100	80	20	40	2.5	12	116	7	34	95.3	5	28	22.5	6	1.0	36
GHPG115-5	5:1	115	8.5	130	110	24	50	3.0	14	145	8	40	117.5	7	32	27.0	8	1.5	40
GHPG115-8	8:1	115	8.5	130	110	24	50	3.0	14	145	8	40	117.5	7	32	27.0	8	1.5	40
GHPG115-10	10:1	115	8.5	130	110	24	50	3.0	14	145	8	40	117.5	7	32	27.0	8	1.5	40
GHPG115-15	15:1	115	8.5	130	110	24	50	3.0	14	145	8	40	117.5	7	32	27.0	8	1.5	40
GHPG115-20	20:1	115	8.5	130	110	24	50	3.0	14	145	8	40	117.5	7	32	27.0	8	1.5	40
GHPG115-30	30:1	115	8.5	130	110	24	50	3.0	14	145	8	40	117.5	7	32	27.0	8	1.5	40
GHPG115-50	50:1	115	8.5	130	110	24	50	3.0	14	145	8	40	117.5	7	32	27.0	8	1.5	40
GHPG115-100	100:1	115	8.5	130	110	24	50	3.0	14	145	8	40	117.5	7	32	27.0	8	1.5	40

PLANETARY GEAR HEAD PERFORMANCE SPECIFICATIONS

STOCK NO.	RATED OUTPUT TOR. Nm	BACKLASH OUTPUT TOR. Nm	RATED INPUT SP. RPM	*BACK LASH MIN.	AVE. EFF. %	MOM. OF IN. kg-m ²	TOR. STIFF. Nm/min	MAX. WEIGHT kg	RAD LOAD ⁽¹⁾ N	AXIAL LOAD N
60 Series	33.9	56.3	5000	10	90	4x10 ⁻⁶	5.7	1.4	1779.4	1079.4
90 Series	90.4	150.1	5000	10	90	2x10 ⁻⁵	9.0	3.2	2669.0	2669.0
115 Series	180.2	300.1	5000	10	90	5x10 ⁻⁵	15.0	7.3	4893.2	4893.2

* 5 minute backlash available on request

⁽¹⁾ Radial loads are at 25.4mm from the face of the gear head.

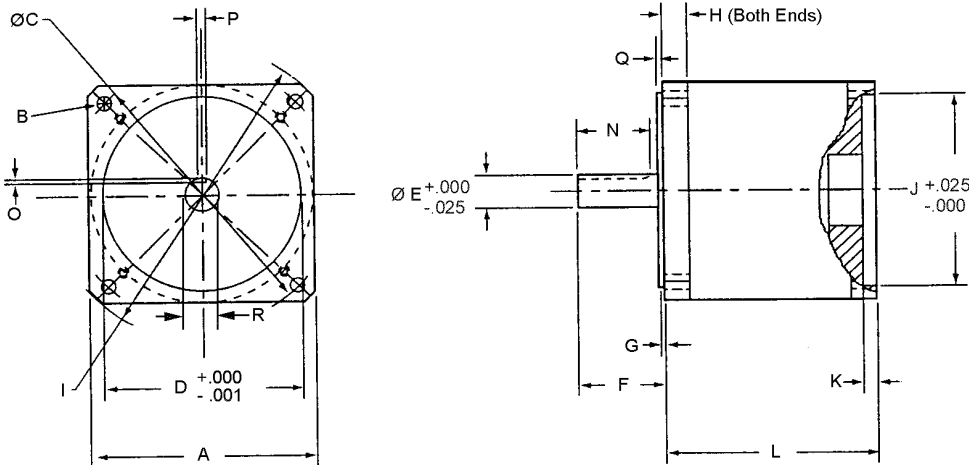

Materials:

- Housing - Anodized Aluminum
- Gears - Stainless Steel Q12 / DIN 7 Quality Class
- Shafts - Stainless Steel
- Bearings - Stainless Steel or Bronze
- Lubrication - Sny. Grease

INTERMITTENT MOTION ASSEMBLY

SHAFT	TYPE
6MM	BALL BEARING

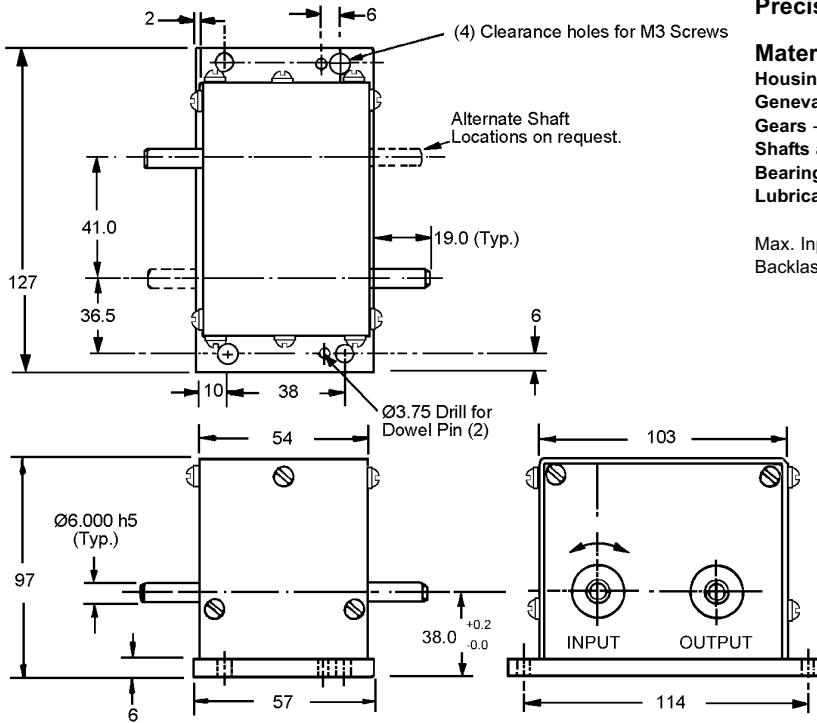

Precision Geneva Mechanism

Materials:

Housing and Cover - Anodized Aluminum

Geneva - Stainless Steel

Gears - Stainless Steel and Aluminum

Shafts and Hardware - Stainless Steel

Bearings - Stainless Steel - ABEC 7

Lubrication - Grease

Max. Input Speed - 300 RPM

Backlash at Output Shaft - 30 Minutes Max.

PRECISION BALL BEARING UNIT	ROTATION OF OUTPUT SHAFT PER EACH 360° REV. OF INPUT
STOCK NUMBER	
GX-1M	90 DEGREES
GX-2M	60 DEGREES
GX-3M	45 DEGREES
GX-4M	30 DEGREES
GX-5M	22.5 DEGREES
GX-6M	10 DEGREES

PRECISION BALL BEARING UNIT	ROTATION OF OUTPUT SHAFT PER EACH 180° REV. OF INPUT
STOCK NUMBER	
GX-7M	180 DEGREES
GX-8M	120 DEGREES
GX-9M	90 DEGREES
GX-10M	60 DEGREES
GX-11M	45 DEGREES
GX-12M	20 DEGREES



C

GENEVA MECHANISM

BORE	POINTS	MATERIAL
6 AND 7	4, 5, 6 AND 8	STAINLESS STEEL

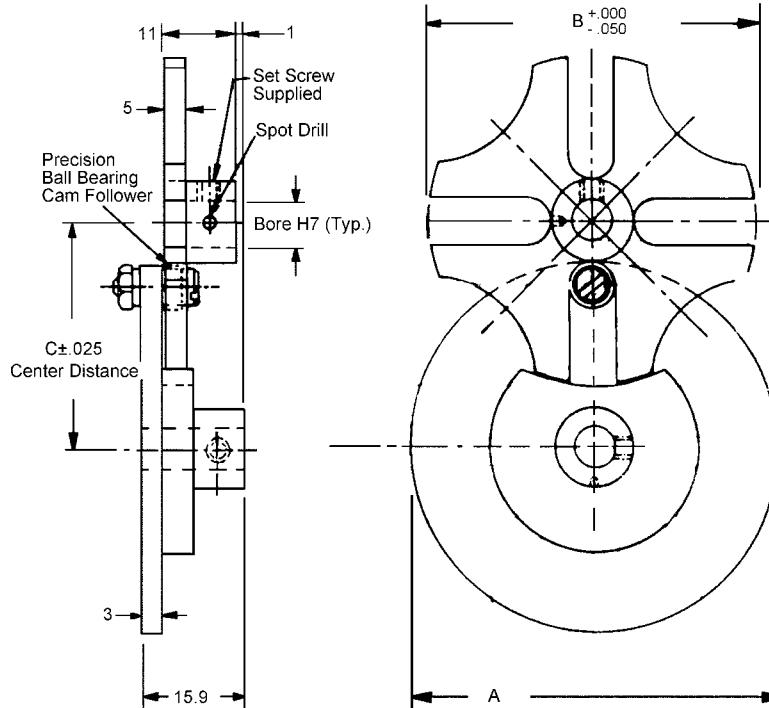

4 POINT DRIVE ILLUSTRATED

STOCK NO.	NO. ROLLERS ON DRIVER	RELATIVE ROTATION DRIVER TO DRIVEN		POINTS ON DRIVEN	MAX. TORQUE (N•cm)	MAX OPER. TORQUE (N•cm)	A	B	C	BORE
GM-1-M GM-1A-M	ONE TWO	360° 180°	90°	4	50	25	57	50	35.11	7
GM-2-M GM-2A-M	ONE TWO	360° 180°	72°	5	78	39	57	63	38.57	7
GM-3-M GM-3A-M	ONE TWO	360° 180°	60°	6	124	62	64	88	50.72	7
GM-4-M GM-4A-M	ONE TWO	360° 180°	45°	8	170	85	51	104	56.02	6

STOCK NO.	DESCRIPTION
JE-1-PH	REPLACEMENT CAM FOLLOWER

Other Bore sizes available on request.



CAM FOLLOWER

TYPE	MATERIAL	ABEC
BALL BEARING OR OIL-LESS BRONZE BEARING	STAINLESS STEEL	5

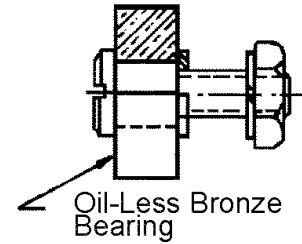
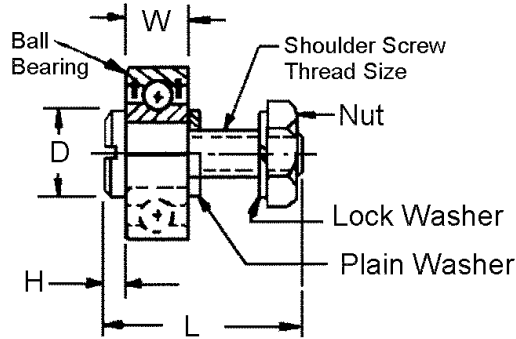
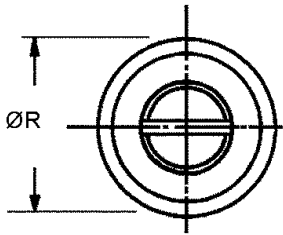

STOCK NO.	ØR	W	L	D	H	SCREW THREAD	BEARING
JEM-10	7.00	3.0	12.0	5	3	M3.0 X 0.5	BALL BEARING
JEM-11	9.00	4.0	11.0	6	3	M3.0 X 0.5	
JEM-12	11.00	5.0	13.0	8	4	M4.0 X 0.7	
JEM-13	13.00	4.0	14.0	8	4	M4.0 X 0.7	
JEM-14	16.00	5.0	13.0	8	4	M4.0 X 0.7	
JEM-15	19.00	6.0	17.0	10	5	M5.0 X 0.8	
JEM-B-11	8.00	4.0	11.0	6	3	M3.0 X 0.5	BRONZE BEARING
JEM-B-12	10.00	5.0	14.0	8	4	M4.0 X 0.7	
JEM-B-13	13.00	5.0	14.0	8	4	M4.0 X 0.7	
JEM-B-14	16.00	5.0	16.0	10	5	M5.0 X 0.8	

MATERIALS

Bearings - Stainless Steel or Bronze

Screw - Stainless Steel DIN 1.4005

Hardware - Stainless Steel



C

ROLLER BEARING CAM FOLLOWER

TYPE

HEAVY DUTY

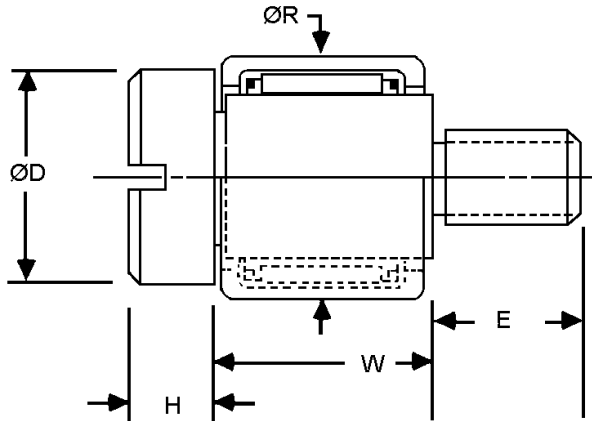

Materials:

Screw - Stainless Steel DIN 1.4005

Roller Cup - Case Hardened Steel

Needle Bearings - Hardened Steel

Bearing Cage - Low Carbon Steel

See the Bearings Section of this book for Bearings Specifications.

STOCK NO.	$\varnothing R$	W	$\varnothing D$	H	E	SCREW THREAD
JEM-R-1	8.00	8.00	6.0	2.7	4	M3 X 0.5
JEM-R-3	9.00	9.00	8.0	4.0	5	M4 X 0.7
JEM-R-4	10.00	9.00	8.5	5.0	6	M5 X 0.8
JEM-R-5	12.00	10.00	10.5	5.7	11	M6 X 1.0
JEM-R-6	14.00	10.00	12.5	6.7	12	M8 X 1.25
JEM-R-8	16.00	12.00	14.5	7.7	16	M10 X 1.50

- High Load
- Low Profile
- Low Friction

RATCHETS AND PAWLS

PITCH	STYLE	MATERIAL
16 to 48	RIGHT HAND OPERATION	STAINLESS STEEL

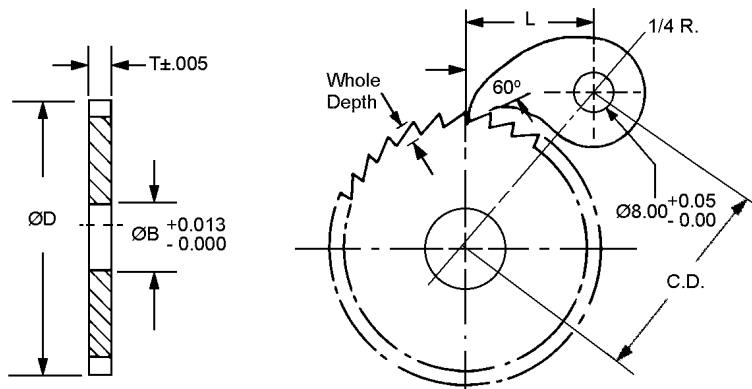

17-4 PH STAINLESS STEEL HARDENED RC 32-38			416 STAINLESS STEEL
STOCK PAWLS			MOUNTING SHOULDER SCREW (Order Separately)
STOCK NO.	T THICKNESS	L LENGTH	
RP-2M	6.2	19	PLM-28
RP-375M	9.4	33	PLM-30

- For Shoulder Screw Dimensions - See Index
- Ratchets Material - 303 Stainless Steel
- Last number in Stock No. indicate the total number of teeth. Special ratchets and pawls made to order, contact us.

RATCHET STOCK NO.	PITCH	OUTSIDE DIA.	BORE	T	C.D. +.06 -.00	WHOLE DEPTH	PAWL STOCK NO
R16S120-20	16	31.7	16	9.5	38.9	3.1	RP-375M
R16S120-24		38.1			40.6		
R16S120-32		50.8			44.5		
R16S120-48		76.2			53.3		
R16S120-56		88.9			58.4		
R16S120-65	101.6	63.5					
R24S106-24	24	25.4	10	6.4	28.2	1.8	RP-2M
R24S106-30		31.7			30.0		
R24S106-36		38.1			32.0		
R24S106-48		50.8			36.8		
R24S106-72		76.2			47.2		
R32S103-24	32	19.0	10	3.0	26.4	1.5	RP-2M
R32S103-32		25.4			28.2		
R32S103-40		31.7			30.0		
R32S103-48		38.1			32.0		
R32S103-64		50.8			36.8		
R32S103-96	76.2	47.2					
R48S103-36	48	19.0	10	3.0	26.2	0.9	RP-2M
R48S103-48		25.4			28.4		
R48S103-60		31.7			30.5		
R48S103-72		38.1			32.5		
R48S103-96		50.8			37.3		
R48S103-144	76.2	47.8					



C

